

Lorch S-RoboMIG XT

ROBOT WELDING PACKAGES

for ABB

S-RoboMIG XT

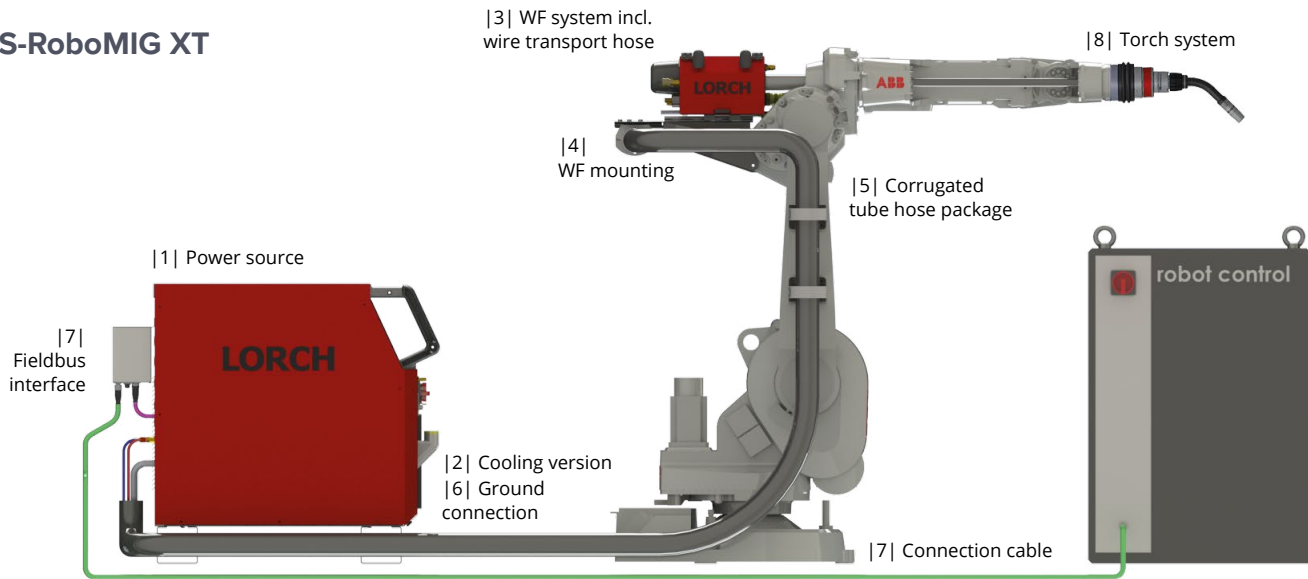

Welding packages for ABB IRB 1660ID

	Robotic packages S3 RoboMIG XT	Robotic packages S5 RoboMIG XT	Robotic packages S8 RoboMIG XT
Power source equipment	G	W	W
1 Welding current	25 – 320 A	25 – 400 A	25 – 500 A
1 Duty cycle	320 A 40% 250 A 100%	400 A 50% 320 A 100%	500 A 60% 400 A 100%
1 Power source version	SpeedPulse version, including gas-pressure monitoring (integrated in power source) (processes included: SpeedPulse XT, SpeedPulse, SpeedArc XT, TwinPuls XT, Pulse, MIG-MAG-Synergy)		
2 Cooling version	Gas-cooled	Water-cooled	Water-cooled
3 Wire feed system	RF-06 (4 rolls/2 driven, steel 1.0/1.2 mm, Euro connector) incl. 6 m wire transport hose (can be shortened)		
4 Wire feed mounting	Mounting plate – matching the robot type (with sliding system for easier torch maintenance)		
5 Interconnection hose package	Corrugated tube hose package with compressed air line 50 mm ² , 5 m or 10 m	Corrugated tube hose package with compressed air line 70 mm ² , 5 m or 10 m	Corrugated tube hose package with compressed air line 95 mm ² , 5 m or 10 m
6 Ground connection	Welding return cable 95 mm ² with cable shoe (for screw connection M12)		
7 Fieldbus interface	LorchNet connector Ethernet/IP** incl. 5 m connection cable to robot control, plus additional I/O socket		
Torch equipment			
8 Torch type	LMR 2 – TN 6 CTC G	LMR 2 – TN 6 CTC W	LMR 2 – TN 6 CTC W
Duty cycle	Mix 300 A 100% CO ₂ 350 A 100%	Mix 450 A 100% CO ₂ 500 A 100%	Mix 450 A 100% CO ₂ 500 A 100%
Torch hose package	LMR 2 – HP 30-G (HW,SO) with Euro connector – length matching robot type (+/- 270° turning range)	LMR 2 – HP 30-W (HW,SO) with Euro connector – length matching robot type (+/- 270° turning range)	LMR 2 – HP 30-W (HW,SO) with Euro connector – length matching robot type (+/- 270° turning range)
Torch neck/holder bend	45°		
Safety equipment	HW hose package – with integrated safety deactivation		
Starter kit wear parts	Incl. wear parts for steel 1.0/1.2 mm		
Order information welding packages			
Package name	Robotic package for ABB IRB 1660ID – S3 RoboMIG XT G	Robotic package for ABB IRB 1660ID – S5 RoboMIG XT W	Robotic package for ABB IRB 1660ID – S8 RoboMIG XT W
Package order number (5 m)*	230.9113.1	230.9115.5	230.9118.5
Package order number (10 m)*	230.9113.2	230.9115.6	230.9118.6

* Length of interconnection hose package

S-RoboMIG XT

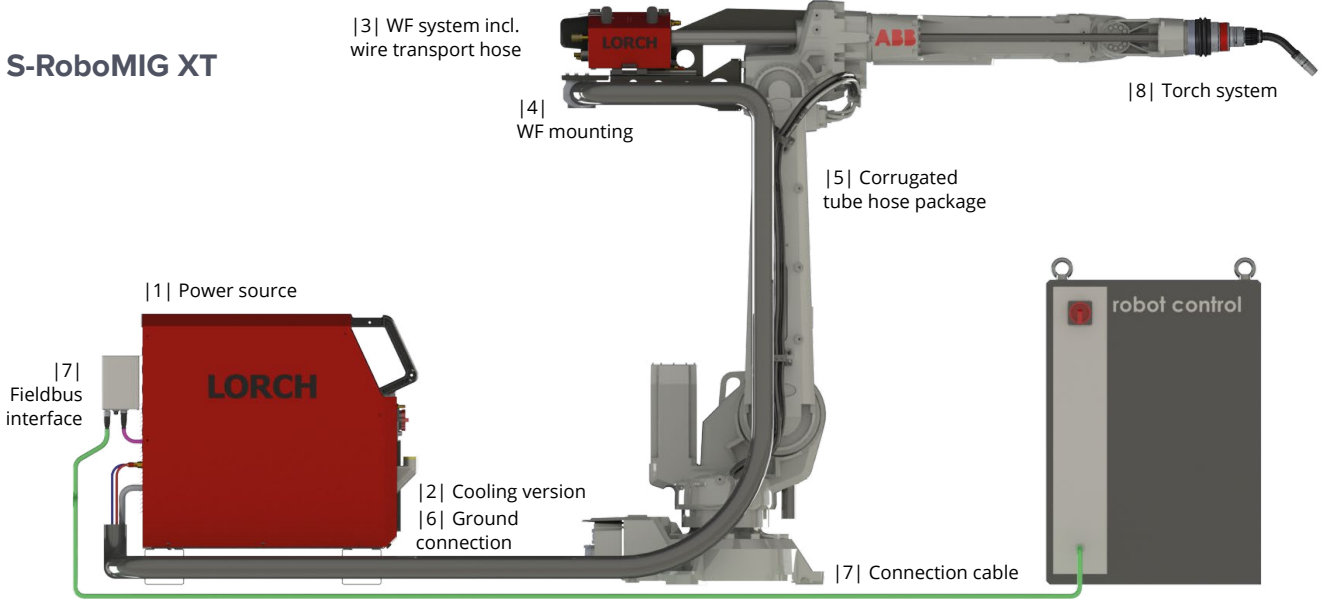



Welding packages for ABB IRB 2600ID

	Robotic packages S3 RoboMIG XT	Robotic packages S5 RoboMIG XT	Robotic packages S8 RoboMIG XT
Power source equipment	G	W	W
1 Welding current	25 – 320 A	25 – 400 A	25 – 500 A
1 Duty cycle	320 A 40% 250 A 100%	400 A 50% 320 A 100%	500 A 60% 400 A 100%
1 Power source version	SpeedPulse version, including gas-pressure monitoring (integrated in power source) (processes included: SpeedPulse XT, SpeedPulse, SpeedArc XT, TwinPuls XT, Pulse, MIG-MAG-Synergy)		
2 Cooling version	Gas-cooled	Water-cooled	Water-cooled
3 Wire feed system	RF-06 (4 rolls/2 driven, steel 1.0/1.2 mm, Euro connector) incl. 6 m wire transport hose (can be shortened)		
4 Wire feed mounting	Mounting plate – matching the robot type (with sliding system for easier torch maintenance)		
5 Interconnection hose package	Corrugated tube hose package with compressed air line 50 mm ² , 5 m or 10 m	Corrugated tube hose package with compressed air line 70 mm ² , 5 m or 10 m	Corrugated tube hose package with compressed air line 95 mm ² , 5 m or 10 m
6 Ground connection	Welding return cable 95 mm ² with cable shoe (for screw connection M12)		
7 Fieldbus interface	LorchNet connector DeviceNet incl. 5 m connection cable to robot control, plus additional I/O socket		
Torch equipment			
8 Torch type	LMR 2 – TN 6 CTC G	LMR 2 – TN 6 CTC W	LMR 2 – TN 6 CTC W
Duty cycle	Mix 300 A 100% CO ₂ 350 A 100%	Mix 450 A 100% CO ₂ 500 A 100%	Mix 450 A 100% CO ₂ 500 A 100%
Torch hose package	LMR 2 – HP 30-G (HW,SO) with Euro connector – length matching robot type (+/- 270° turning range)	LMR 2 – HP 30-W (HW,SO) with Euro connector – length matching robot type (+/- 270° turning range)	LMR 2 – HP 30-W (HW,SO) with Euro connector – length matching robot type (+/- 270° turning range)
Torch neck/holder bend	45°		
Safety equipment	HW hose package – with integrated safety deactivation		
Starter kit wear parts	Incl. wear parts for steel 1.0/1.2 mm		
Order information welding packages			
Package name	Robotic package for ABB IRB 2600ID – S3 RoboMIG XT G	Robotic package for ABB IRB 2600ID – S5 RoboMIG XT W	Robotic package for ABB IRB 2600ID – S8 RoboMIG XT W
Package order number (5 m)*	230.9123.1	230.9125.5	230.9128.5
Package order number (10 m)*	230.9123.2	230.9125.6	230.9128.6

* Length of interconnection hose package



Optional accessories for robot welding packages

Remote control	
Version	Order no.
 <p>Manual remote control HR 918 including 5 m connection cable to the power source</p>	570.2211.0

Bulk pack accessories	
Version	Order no.
 <p>Drum adapter with quick-action coupling</p>	612.6027.0

Wire spool holder	
Version	Order No.
 <p>Wire spool holder external (for wall anchoring)</p> <p>Sample photo Delivery always inclusive plastic wire spool cover</p>	450.0028.0

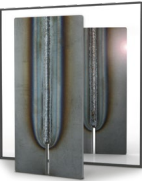
Inter-connection hose package mounting	
Version	Order No.
 <p>Hose package holder (set of 2 holding clips)</p> <p>Sample photo</p>	612.1165.0

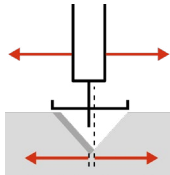
Welding process and functional upgrades							
SpeedUp		SpeedRoot		SpeedCold		Seam tracking	
 <p>360° operation. Weld vertical seams and other fixed positions quickly and with perfect ease and process reliability.</p>		 <p>Top-tier gap bridging. Challenging root welding made easy.</p>		 <p>Reduced heat input. Ideal for thin metal sheets.</p>		 <p>Special software signal suitable both for vertical and horizontal adjustment of the torch guidance.</p>	
Order no.	575.1002.0	Order no.	575.1011.0	Order no.	575.1013.0	Order no.	575.1021.0

All upgrades require Windows-PC/laptop plus Lorch CAN-dongle set 570.2224.9 for installation.

Additional wire feeder rolls for steel/stainless steel			
Version		Order no.	Ordering note
	Feed roll 0.8/1.0	620.8709.0	Always order wire feed rolls in pairs
	Feed roll 0.9/1.2	620.8939.0	
	Feed roll 1.0/1.2*	620.8941.0	
	Feed roll 1.2/1.6	620.8942.0	

*including as standard in the robot welding packages

Additional torch equipment for stainless steel and aluminium	
Version	Order no.
LMR 2 – HP A-set AL/CrNi (1.0/1.2)	546.0000.2

Pressure reducer	
Version	Order no.
 <p>Pressure reducer Pro Ar/Co2 C 200 bar 32/24</p>	570.9265.0

Aluminium applications
Lorch robotic welding machines are also available as push-pull systems for aluminium applications upon request.